

# END IDLING IN YOUR FLEET

ENGINES CAN'T POLLUTE AT **ZERORPM**<sup>®</sup>  
IDLE MITIGATION SYSTEMS<sup>®</sup>

## EM100E12V

ZeroRPM energy modules are a safe and space efficient solution when you want to add lithium power to your vehicle. This module is designed to power lights, radios, computers, inverters and other electronics with your engine off. Energy Modules of the same voltage may be added in parallel to increase the run time of your system. Energy modules contain an on-board battery management system. ZeroRPM energy modules use lightweight \*lithium-iron batteries. This chemistry makes ZeroRPM battery technology among the safest on the market. This unit can be charged using 12V power from an alternator, solar panels, or other 12V power source.

**Note:** This product requires other ZeroRPM IMS components. Reference [ZeroRPM.com/systems](http://ZeroRPM.com/systems) for more information.

*\*"Lithium-Iron" is marketing term for ZeroRPM's LiFeMnPO4 packaged energy storage systems.*

### SYSTEM BENEFITS:

- IMPROVE OPERATOR SAFETY
- ENGINE-OFF AIR CONDITIONING
- REDUCE OPERATING COST
- PROTECT THE ENVIRONMENT
- LIGHT WEIGHT
- SMALL FORM FACTOR

### SPECIFICATIONS:

Total Energy	1.28 kWh
Usable Energy	1.00 kWh
Current Limit Export	250A @ 100% Duty Cycle @12V
Export Voltage	12V-14.1V
Charge Voltage	12V-14.2V
Nominal Voltage	12.8V
Battery Chemistry	Lithium-Iron (LiFeMnPO4)
Internal Fuse Rating Battery Protection (Slow Blow)	300A
Product Housing Material	Powder-coated Aluminum
Weight	41.5 lbs / 18.8 kg
Charging Temperature Range*	32°F to 150°F / 0°C to 65.6°C
Discharge Temperature Range*	-4°F to 150°F / -20°C to 65.6°C
Number of 12V Battery Packs	1

\*Temperatures are based on software versions 4.94.00 and later with battery SOC of >40%.

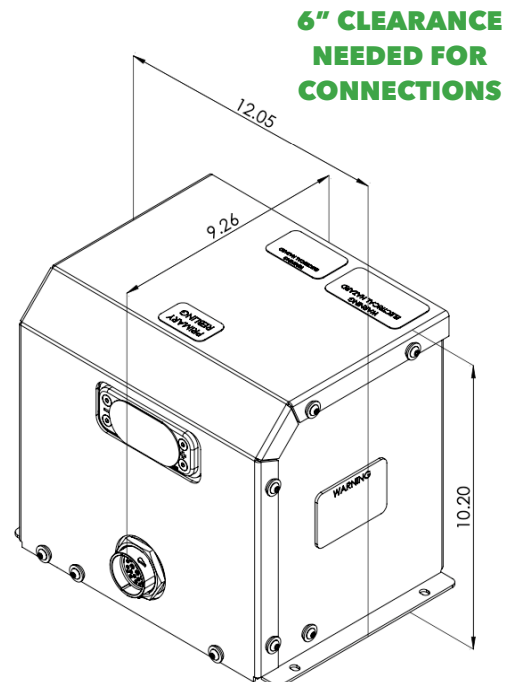

**Ask for ZeroRPM<sup>®</sup> Idle Mitigation Systems<sup>®</sup> WHERE you purchase your fleet vehicles!**

# END IDLING

## IN YOUR FLEET



### EM100E12V

**ALL DIMENSIONS ARE IN INCHES**

**FOR WIRING OF THE SYSTEM PLEASE REFERENCE THE SYSTEM SCHEMATIC**

**6" CLEARANCE NEEDED FOR CONNECTIONS**

#### OVERALL DIMENSIONS

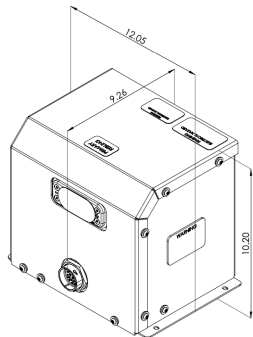

**FRONT**

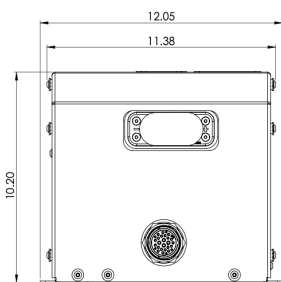

#### SIGNAL CONNECTION



**29 PIN BATTERY MANAGEMENT CONNECTOR**

#### POWER CONNECTION



**12V POWER 2-CABLE REBLING CONNECTOR**

**TOP**

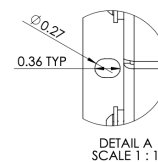
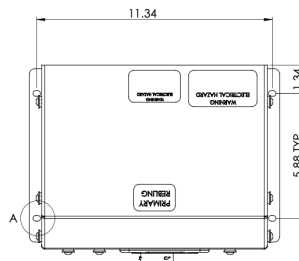

**SIDE**

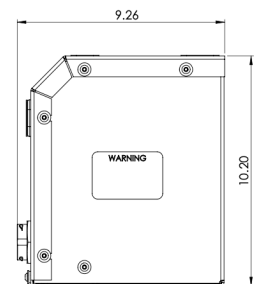

## PRODUCT NOTES:

- Storage temperature: -4 °F to 149 °F / -20 °C to 65 °C.
- The unit must be mounted securely and upright.
- In shipping or storage, do not stack more than one product on top of one another (i.e. two unit stack maximum).
- The unit must be mounted so the lid is removable.
- The unit must be mounted as closely to the loads and supply as possible.
- If the unit has been in storage for more than 90 days, the voltage must be checked to ensure that the batteries have not discharged past the acceptable threshold.
- There must be adequate provisions for drainage below the unit to prevent flooding.
- There must be at least 6" of clearance on the right side of the unit for the main power connectors.
- The unit must be mounted in a well-ventilated compartment. In extreme hot or cold environments, it is ideal to mount the unit in a temperature controlled compartment.
- The unit must be mounted with vibration-dampening material. The material must be installed between the unit's feet and the mounting surface.
- Exporting at maximum current for an extended amount of time will substantially reduce the life of the battery pack.
- Do not put the unit on its side or upside down without written approval from ZeroRPM.
- Do not extend the current shunt wires (if current shunt wires are present).